

性能表/Performance table

泵型号 Model	参考型号 Reference model	功率 Power P ₂ (kW)	流量 Q (m ³ /h)	扬程 H (m)											
				80	90	100	110	120	130	140	150	160	170	180	
CVFA150-1-1	CDLF150-10-1	11		18.3	17.8	17.3	17	16	15	14	13	11	10	8.5	
CVFA150-1	CDLF150-10	15		24	23	22.5	22	21.5	20.5	20	19	17	16	15	
CVFA150-2-2	CDLF150-20-2	18.5		37	35.5	34	33	32	31	29	28	26	23	21	
CVFA150-2-1	CDLF150-20-1	22		44.5	43	42	40	39	38.5	37.5	35	33	30	27	
CVFA150-2	CDLF150-20	30		50	49	48	47	45.5	44	42	40	37	34	32	
CVFA150-3-2	CDLF150-30-2	30		63.5	61	59	57.5	56	54.5	53	49	45.5	42	39	
CVFA150-3-1	CDLF150-30-1	37		70	68	67	65	63	62	60	56	53	49	45	
CVFA150-3	CDLF150-30	37		78	76.5	75	73	70.5	68	66	63	59	55	50.5	
CVFA150-4-2	CDLF150-40-2	45		89	87	84	81.5	79	77	74.5	71	65.5	60	56	
CVFA150-4-1	CDLF150-40-1	45		96.5	94	91.5	89	86.5	84	81.5	77	72.5	67	62	
CVFA150-4	CDLF150-40	55		104	102	100	97	95	91	88	84	79.5	74	68	
CVFA150-5-2	CDLF150-50-2	55		115.5	112	109	106	102.5	100	97	92	86	79	73.5	
CVFA150-5-1	CDLF150-50-1	75		122.5	119.5	117	113.5	111.5	107.5	104.5	99	93.5	87	80	
CVFA150-5	CDLF150-50	75		130	127.5	125	121	119	115	111.5	107	101	94.5	86.5	
CVFA150-6-2	CDLF150-60-2	75		140	137	133	130	126	121	118	112	106	98	91	
CVFA150-6-1	CDLF150-60-1	75		148.5	145	141.5	137.5	135	131	127	121	114.5	106.5	97.5	
CVFA150-6	CDLF150-60	75		157	153	149	145	142	139.5	137	130	123.5	116	109	

安装图/Installation sketch

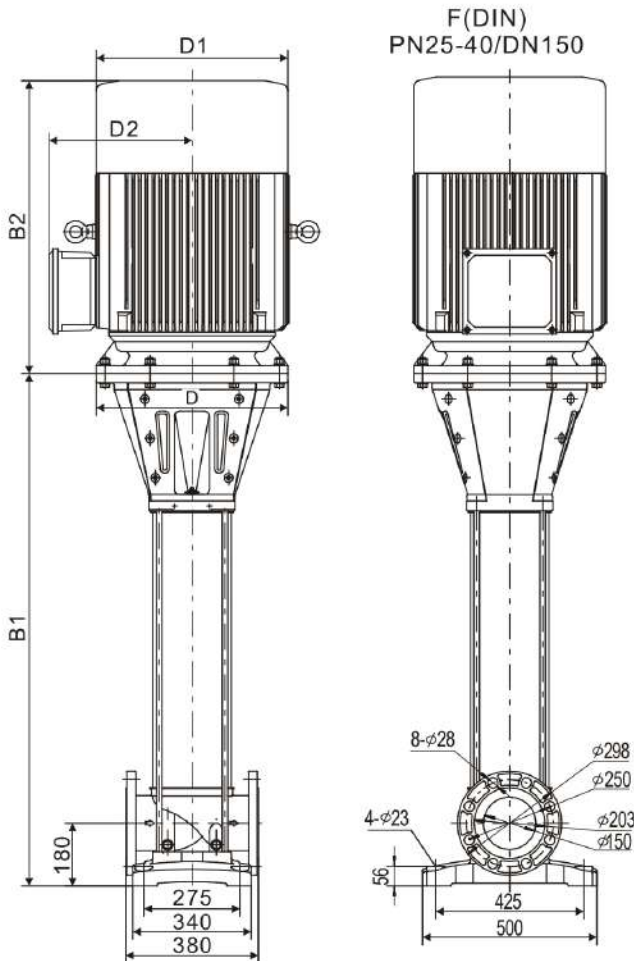

泵型号 Model	尺寸/Dimensions(mm)					
	B1	B2	B1+B2	D1	D2	D
CVFA150-1-1	826	448	1274	255	182	250
CVFA150-1	826	489	1315	255	182	250
CVFA150-2-2	978	542	1520	313	257	250
CVFA150-2-1	978	580	1558	356	270	250
CVFA150-2	982	653	1635	395	304	300
CVFA150-3-2	1134	653	1787	395	304	300
CVFA150-3-1	1134	653	1787	395	304	300
CVFA150-3	1134	653	1787	395	304	300
CVFA150-4-2	1286	702	1988	450	340	450
CVFA150-4-1	1286	702	1988	450	340	450
CVFA150-4	1316	772	2088	490	370	550
CVFA150-5-2	1468	772	2240	490	370	550
CVFA150-5-1	1468	840	2308	550	410	550
CVFA150-5	1468	840	2308	550	410	550
CVFA150-6-2	1620	840	2460	550	410	550
CVFA150-6-1	1620	840	2460	550	410	550
CVFA150-6	1620	840	2460	550	410	550

性能曲线/Performance Curve

CVFA150-50Hz

