

性能表/Performance table

泵型号 Model	参考型号 Reference model	功率 Power P ₂ (kW)	流量 Q (m ³ /h)	扬程 H (m)									
				0.4	0.6	0.8	1.0	1.2	1.4	1.6	1.8	2.0	2.2
CVLA1-2	CDLF1-2	0.37		12	11.8	11.5	11	11	10.5	9.8	9.2	8.5	7.8
CVLA1-3	CDLF1-3	0.37		17.5	17	16.8	16.5	16	15.5	14	13.5	12	10.5
CVLA1-4	CDLF1-4	0.37		23.5	23	22.5	22	21	20.5	18.5	18	16.5	14
CVLA1-5	CDLF1-5	0.37		29	28.5	28	27.5	26.5	26	24	23	20.5	17.5
CVLA1-6	CDLF1-6	0.37		35	34.5	34	33	32	31	28	27	25	22
CVLA1-7	CDLF1-7	0.37		41	40	39	38.5	37	35	33	32	29	25
CVLA1-8	CDLF1-8	0.55		46.5	46	45.5	44	42	40	38	36	33	29
CVLA1-9	CDLF1-9	0.55		52	51.5	51	49.5	47.5	46	44	41	37	34
CVLA1-10	CDLF1-10	0.55		58	57.5	57	56	54	52	48	46	41.5	37
CVLA1-11	CDLF1-11	0.55		65	63	62.5	61	59	56	54	50	46	40
CVLA1-12	CDLF1-12	0.75		70	69	68	66	64	62	58	55	49	43
CVLA1-13	CDLF1-13	0.75		75	74.5	74	72	69	66	63	59	54	47
CVLA1-15	CDLF1-15	0.75		87	86	85	84	80.5	77	72	68	62	53
CVLA1-17	CDLF1-17	1.1		99	97.5	97	95	91	87	81.5	70	69	59
CVLA1-19	CDLF1-19	1.1		110.5	109	108	106	101	97	91	86	78	66
CVLA1-21	CDLF1-21	1.1		122	120.5	119.5	116	112	108	101	95	86	73
CVLA1-23	CDLF1-23	1.1		135	132.5	130	126	122	117	111	104	94	80
CVLA1-25	CDLF1-25	1.5		147	144	141	138	133	128	121	114	103	87
CVLA1-27	CDLF1-27	1.5		158	156	154	150	144	138	130	121	112	96
CVLA1-30	CDLF1-30	1.5		175	173	171	166	160	154	145	136	124	108
CVLA1-33	CDLF1-33	2.2		193	191	188	183	176	170	160	150	136	120
CVLA1-36	CDLF1-36	2.2		212	209	205	200	192	184	174	164	150	133

安装图/Installation sketch

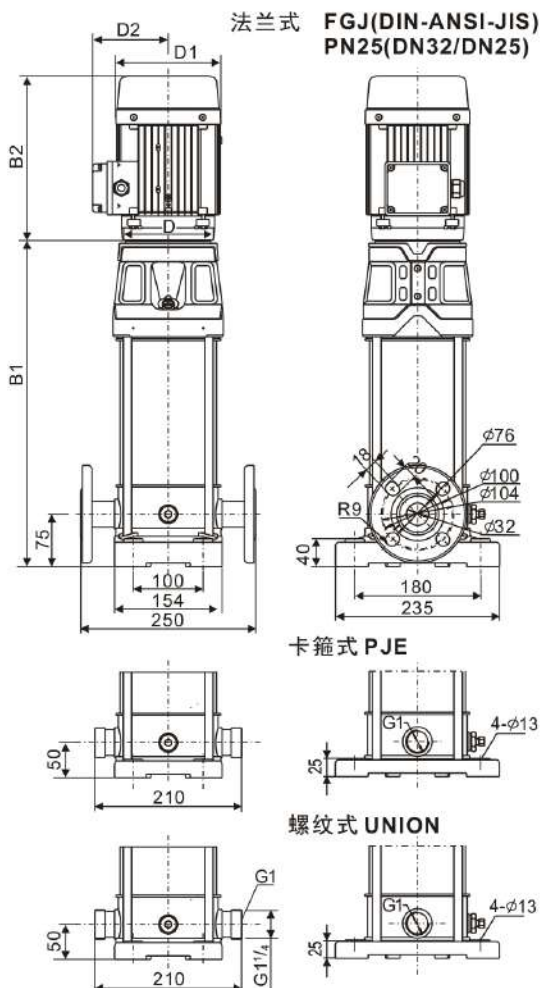

泵型号 Model	尺寸/Dimensions(mm)										
	单相 single phase					三相 Three phase					D
	B1	B2	B1+B2	D1	D2	B1	B2	B1+B2	D1	D2	
CVLA1-2	258	207	465	134	124	258	207	465	134	112	107
CVLA1-3	276	207	483	134	124	276	207	483	134	112	107
CVLA1-4	294	207	501	134	124	294	207	501	134	112	107
CVLA1-5	312	207	519	134	124	312	207	519	134	112	107
CVLA1-6	330	207	537	134	124	330	207	537	134	112	107
CVLA1-7	348	207	555	134	124	348	207	555	134	112	107
CVLA1-8	366	207	573	134	124	366	207	573	134	112	107
CVLA1-9	384	207	591	134	124	384	207	591	134	112	107
CVLA1-10	402	207	609	134	124	402	207	609	134	112	107
CVLA1-11	420	207	627	134	124	420	207	627	134	112	107
CVLA1-12	438	207	645	134	124	438	207	645	134	112	107
CVLA1-13	456	207	663	134	124	456	207	663	134	112	107
CVLA1-15	492	207	699	134	124	492	207	699	134	112	107
CVLA1-17	538	240	778	150	133	538	240	778	150	118	121
CVLA1-19	574	240	814	150	133	574	240	814	150	118	121
CVLA1-21	610	240	850	150	133	610	240	850	150	118	121
CVLA1-23	646	240	886	150	133	646	240	886	150	118	121
CVLA1-25	692	300	992	168	147	682	240	922	150	118	121
CVLA1-27	728	300	1028	168	147	718	240	958	150	118	121
CVLA1-30	782	300	1082	168	147	772	240	1012	150	118	121
CVLA1-33	836	300	1136	168	147	836	280	1116	168	127	135
CVLA1-36	890	300	1190	168	147	890	280	1170	168	127	135

性能曲线/Performance Curve

CVLA1-50Hz

