

性能表/Performance table

泵型号 Model	参考型号 Reference model	功率 Power P ₂ (kW)	流量 Q (m ³ /h)	1.0	1.2	1.6	2.0	2.4	2.8	3.2	3.5
CVLA2-2	CDLF2-2	0.37	扬程 H (m)	16	15.5	14.5	14	12.5	11	9.5	8
CVLA2-3	CDLF2-3	0.37		23	22.5	21	20	18.5	16	14	12
CVLA2-4	CDLF2-4	0.55		32	31	30	28	26	23	20	16
CVLA2-5	CDLF2-5	0.55		42.5	42	40	37	34.5	30	25	20
CVLA2-6	CDLF2-6	0.75		51	50	47	44	41	36	30	24
CVLA2-7	CDLF2-7	0.75		59	57	55	52	47	41	35	28
CVLA2-9	CDLF2-9	1.1		72	71	67	63	58	51	44	36
CVLA2-11	CDLF2-11	1.1		87	85	80	74	67	59	50	42
CVLA2-13	CDLF2-13	1.5		106	104	99	90	81	71	60	51
CVLA2-15	CDLF2-15	1.5		121	119	112	105	96	85	72	61
CVLA2-18	CDLF2-18	2.2		143	139	133	125	116	105	91	78
CVLA2-22	CDLF2-22	2.2		173	169	162	152	140	126	110	95
CVLA2-26	CDLF2-26	3.0		206	201	191	180	170	155	133	118

安装图/Installation sketch

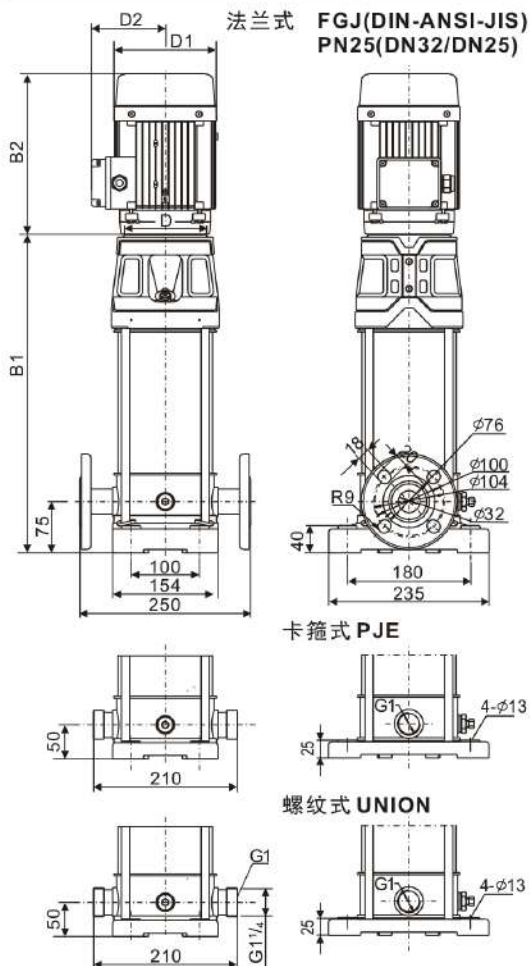

泵型号 Model	尺寸/Dimensions(mm)										D
	单相 single phase					三相 Three phase					
	B1	B2	B1+B2	D1	D2	B1	B2	B1+B2	D1	D2	
CVLA2-2	258	207	465	134	124	258	207	465	134	112	107
CVLA2-3	276	207	483	134	124	276	207	483	134	112	107
CVLA2-4	294	207	501	134	124	294	207	501	134	112	107
CVLA2-5	312	207	519	134	124	312	207	519	134	112	107
CVLA2-6	330	207	537	134	124	330	207	537	134	112	107
CVLA2-7	348	207	555	134	124	348	207	555	134	112	107
CVLA2-9	394	240	634	168	133	394	240	634	150	118	121
CVLA2-11	430	240	670	168	133	430	240	670	150	118	121
CVLA2-13	475	300	776	168	147	466	240	706	150	118	121
CVLA2-15	512	300	812	168	147	502	240	742	150	118	121
CVLA2-18	566	300	866	168	147	566	280	846	168	127	135
CVLA2-22	638	300	938	168	147	638	280	918	168	127	135
CVLA2-26	-	-	-	-	-	710	300	1010	168	127	135

性能曲线/Performance Curve

CVLA2-50Hz

