

性能表/Performance table

泵型号 Model	参考型号 Reference model	功率 Power P ₂ (kW)	流量 Q (m ³ /h)	扬程 H (m)										
				1.2	1.6	2.0	2.4	2.8	3.0	3.2	3.4	3.6	4.0	
CVLA3-2	CDLF3-2	0.37	扬程 H (m)	12	11.3	10.5	10	9	8.5	8	7.5	7	6	
CVLA3-3	CDLF3-3	0.37		18	17	16	15	14	13	12	11	10	8	
CVLA3-4	CDLF3-4	0.37		24	23	21.5	20	18.5	17.5	16.5	15	13.5	11	
CVLA3-5	CDLF3-5	0.37		30	28.5	27	25	23	22	20.5	19	17.5	14	
CVLA3-6	CDLF3-6	0.55		36	34	32	30	28	26	24	22	20	16.5	
CVLA3-7	CDLF3-7	0.55		42	40.5	39	36	33	30.5	28.5	26	24	19.5	
CVLA3-8	CDLF3-8	0.75		48	46	44	41	37	35	32.5	30	27	22.5	
CVLA3-9	CDLF3-9	0.75		53	51	49	46	41.5	39	37	34	32	26	
CVLA3-10	CDLF3-10	0.75		59	57	55	51	46	43	41	37	34	28	
CVLA3-11	CDLF3-11	1.1		65	62.5	60	56	51	48	45	42	38	30.5	
CVLA3-12	CDLF3-12	1.1		71	68	66	61	55	52	49	45.5	42	34	
CVLA3-13	CDLF3-13	1.1		77	74	71	66	60	57	53	50	46	37	
CVLA3-15	CDLF3-15	1.1		88	85	82	77	72	68.5	64	60	55	44	
CVLA3-17	CDLF3-17	1.5		100	97	93	88	83	79	74	69	64	52	
CVLA3-19	CDLF3-19	1.5		112	108	104	98	92	88	83	77	71	58	
CVLA3-21	CDLF3-21	2.2		123	119	115	108	102	97	92	86	79	65	
CVLA3-23	CDLF3-23	2.2		134	130	125	119	110	105	100	94	86	72	
CVLA3-25	CDLF3-25	2.2		146	141	135	128	118	113	108	102	94	79	
CVLA3-27	CDLF3-27	2.2		158	152	146	138	129	123	117	110	103	86	
CVLA3-29	CDLF3-29	2.2		169	163	156	147	137	132	125	118	111	93	
CVLA3-31	CDLF3-31	3.0		180	174	167	157	147	141	134	126	118	100	
CVLA3-33	CDLF3-33	3.0		191	186	178	168	157	150	143	135	127	108	
CVLA3-36	CDLF3-36	3.0		209	203	194	184	173	166	159	151	143	122	

安装图/Installation sketch

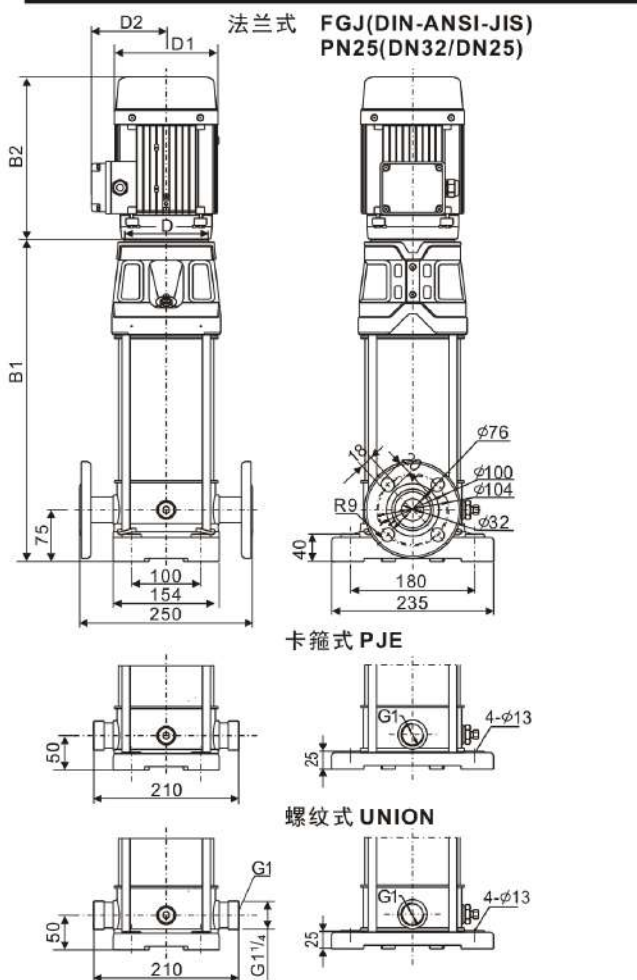

泵型号 Model	尺寸/Dimensions(mm)										
	单相 single phase					三相 Three phase					D
	B1	B2	B1+B2	D1	D2	B1	B2	B1+B2	D1	D2	
CVLA3-2	258	207	465	134	124	258	207	465	134	112	107
CVLA3-3	276	207	483	134	124	276	207	483	134	112	107
CVLA3-4	294	207	501	134	124	294	207	501	134	112	107
CVLA3-5	312	207	519	134	124	312	207	519	134	112	107
CVLA3-6	330	207	537	134	124	330	207	537	134	112	107
CVLA3-7	348	207	555	134	124	348	207	555	134	112	107
CVLA3-8	366	207	573	134	124	366	207	573	134	112	107
CVLA3-9	384	207	591	134	124	384	207	591	134	112	107
CVLA3-10	402	207	609	134	124	402	207	609	134	112	107
CVLA3-11	430	240	670	150	133	430	240	670	150	118	121
CVLA3-12	448	240	688	150	133	448	240	688	150	118	121
CVLA3-13	466	240	706	150	133	466	240	706	150	118	121
CVLA3-15	502	240	742	150	133	502	240	742	150	118	121
CVLA3-17	548	240	848	168	147	538	240	778	150	118	121
CVLA3-19	584	240	884	168	147	574	240	814	150	118	121
CVLA3-21	620	280	920	168	147	620	280	900	168	127	135
CVLA3-23	656	280	956	168	147	656	280	936	168	127	135
CVLA3-25	692	280	992	168	147	692	280	972	168	127	135
CVLA3-27	728	280	1028	168	147	728	280	1008	168	127	135
CVLA3-29	764	280	1064	168	147	764	280	1044	168	127	135
CVLA3-31	-	-	-	-	-	800	300	1100	168	127	135
CVLA3-33	-	-	-	-	-	836	300	1136	168	127	135
CVLA3-36	-	-	-	-	-	890	300	1190	168	127	135

