



Integrated Intelligent Constant Pressure VFD Controlled Pump

Shanghai Lanchuan Automation Technology Co.,Ltd

Add: Room 105, no.755 shenglong road, jiuting town, songjiang district, Shanghai

Tel: +8013611826968

Email: lucky@lanmsl.com

B1100 Series

Integrated Intelligent Constant Pressure VFD Controlled Pump

■ B1100 series integrated intelligent constant pressure VFD Controlled pump have superior performance and rich function, can meet the requirement of water supply in different occasions and improve the quality of water supply system.

■ This series can meet the requirement of New Technologies Products --Energy saving, Water saving, Land saving, Material saving and Environment.



(2.5HP/1.85kW)



(1HP/0.75kW)



(0.7HP/0.55kW)

Technical data

Model	Input Voltage	Output Power P2(kW)	Current (A)	Head (m)	Flow (m ³ /h)	Internally Threaded bore (Inlet/Outlet)
B1100-MLH2031-S20007	Single Phase220V 50/60Hz	0.55	2.0	37	2	G1/G1
B1100-MLH3041-S2001	Single Phase220V 50/60Hz	0.75	3.2	42	3	G1/G1
B1100-MLH8201-S20025	Single Phase220V 50/60Hz	1.85	7.9	36	8	G1½/G1½

External Dimension

B1100 integrated intelligent constant pressure VFD Controlled pump
Remark: a: Outlet, b: Inlet

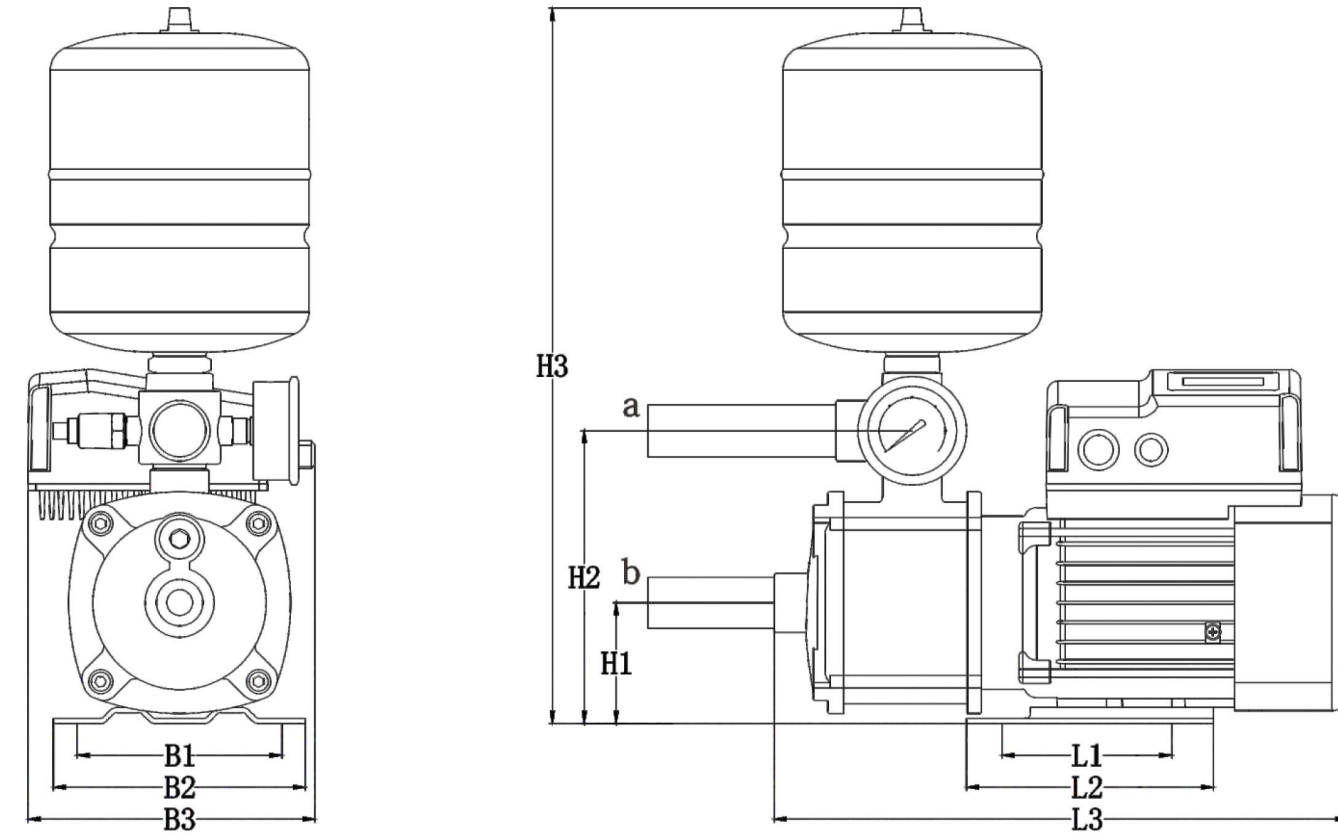

Figure A1-1-1

Model	Dimension(mm)									Packing size (cm)	Weight (kg)
	B3	B2	B1	H3	H2	H1	L3	L2	L1		
B1100-MLH2031-S20007	174	158	125	304	184	75	309	136	96	39.5*22.85*38.5	10
B1100-MLH3041-S2001	181	158	125	475	190	75	350	156	96	42*22.5*47.5	12
B1100-MLH8201-S20025	206	199	160	585	245	100	480	138	96	46*22.5*59	22.5

Features



- Start/stop the pump automatically and Free debugging
- Variable frequency drive to reduce pump power consumption
- Integrated matching design
- High efficiency, saving 20% energy more than exist variable frequency pump
- The fluid pass parts are Stainless steel 304



B1100 Series

Integrated Intelligent Constant Pressure
VFD Controlled Pump

Application



Applicable to Hotel, Villa, Sauna Room, School, Garden Irrigation, etc.

Protection Function

Sensor open circuit protection
protection function: Over-Current, Over-Voltage, Low-Voltage, Phase-Failure and Over-land etc.

Operation conditions

This product is designed for indoor use. If you want to install the product on outdoor areas, prepare facilities that can provide the product with protection against rain, wind and low temperature.

Medium : Clean water · temperature : +15℃~+70℃ ◦

Notes: You must extract the air inside the pump for the first use.

Application Cases



WLD160 Series

Integrated Intelligent Constant Pressure Variable Frequency Pump

WLD160 series integrated intelligent constant pressure variable frequency pump is specially designed based on users' needs which can meet the applications of water supply in different occasions and improve the quality of water supply system.

This series is easy operation economical style pump, which can constant pressure water supply automatically according to the water consumption without manual operation after parameters were set correctly. It is widely applicable to residential area water supply, tap water boosting, garden irrigation and vegetable greenhouse water supply.



External Dimension

WLD160integrated intelligent constant pressure variable frequency pump

Remark: a: Outlet, b: Inlet

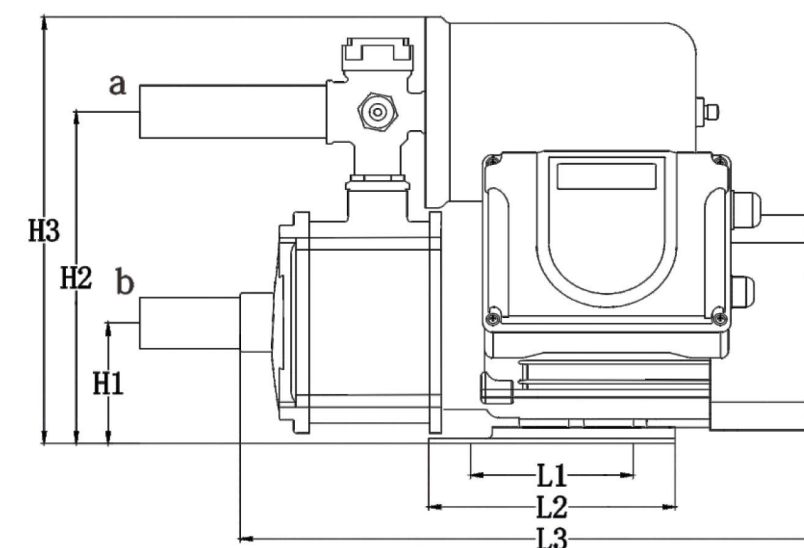
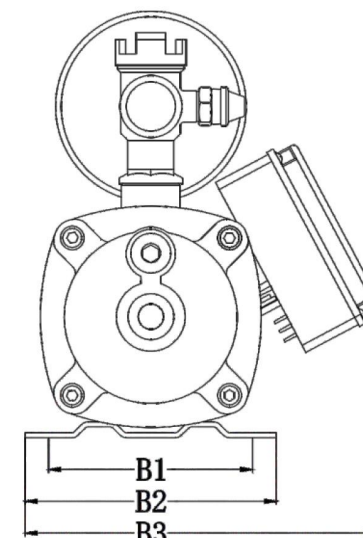

Figure B1-1-1

Model	Dimension(mm)									Packing size (cm)	Weight (kg)
	B3	B2	B1	H3	H2	H1	L3	L2	L1		
WLD160-MLH3041-S2001	220	158	125	266	133.5	75	362	155	96	23.5*20*14	12

Technical data

Model	Input Voltage	Output Power (kW)	Current (A)	Head (m)	Flow (m³/h)	Internally Threaded bore (Inlet/Outlet)
WLD160-MLH3041-S2001	Single Phase220V 50/60Hz	0.75	3.2	42	3	G1/G1

Features



- Auto-control and constant pressure water supply
- Built-in PID control method can realize non-loaded shut down(sleep mode)
- Running automatically when power on(Power on restart)
- Fault parameter record for analysis



WLD160 Series

Integrated Intelligent Constant Pressure Variable Frequency Pump

Operation conditions

This product is designed for indoor use. If you want to install the product on outdoor areas, prepare facilities that can provide the product with protection against rain, wind and low temperature.
Medium: Clean water, temperature: +15~+99°C.

Protection Function

- Over-Voltage and Low-Voltage protection
- Out short circuit protection
- High pressure and low pressure protection
- Output phase failure protection
- Over-load protection
- Pressure transmitter open circuit protection

Application

Separate house, villas, school, hotel and etc.



Application Cases

